

1 PRECAST CATCH BASIN (30"x30" - USED IN PARKING AREAS)
SCALE: N.T.S.

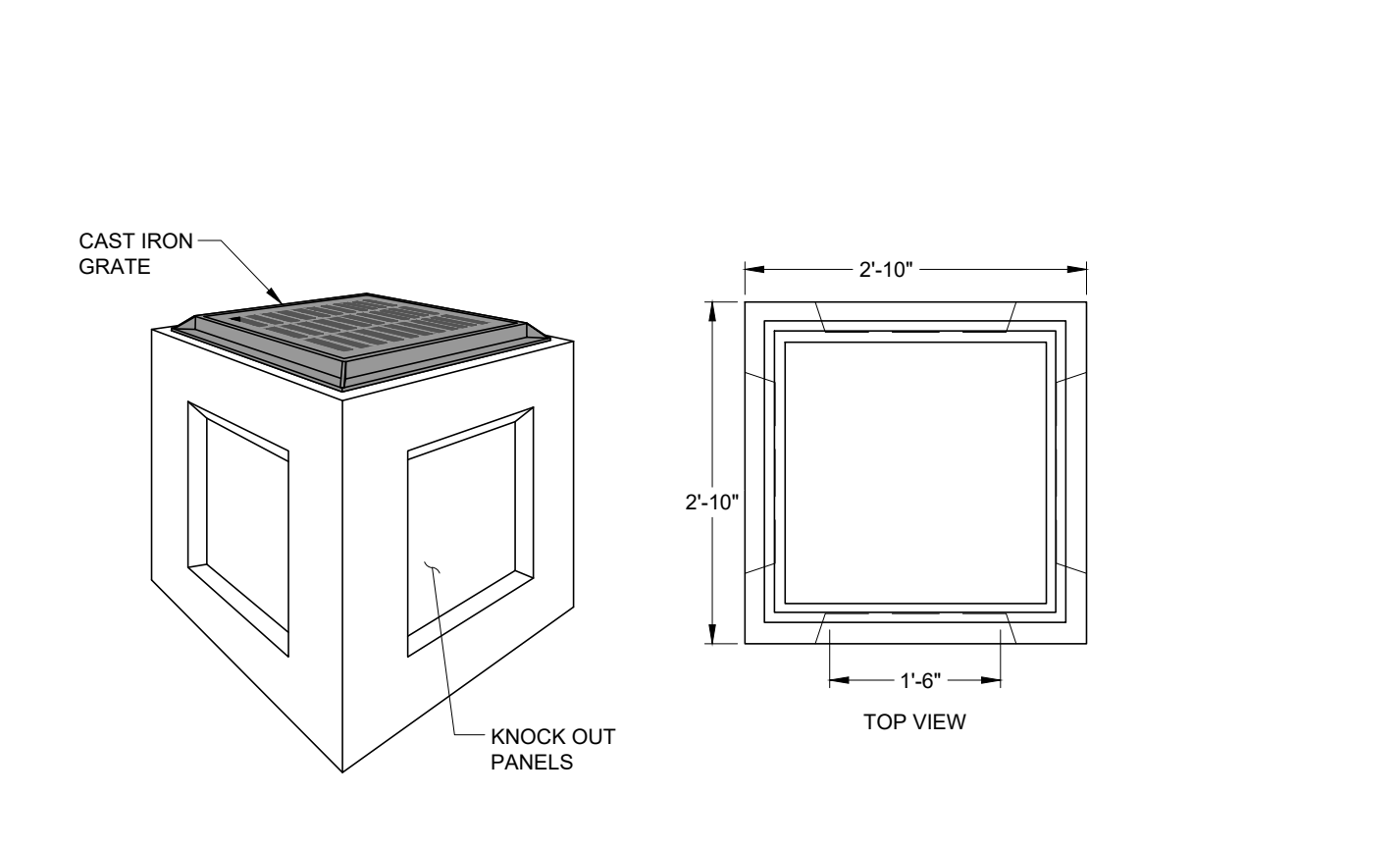

2 PRECAST CATCH BASIN (24"x24" - USED IN PLANTERS)
SCALE: N.T.S.

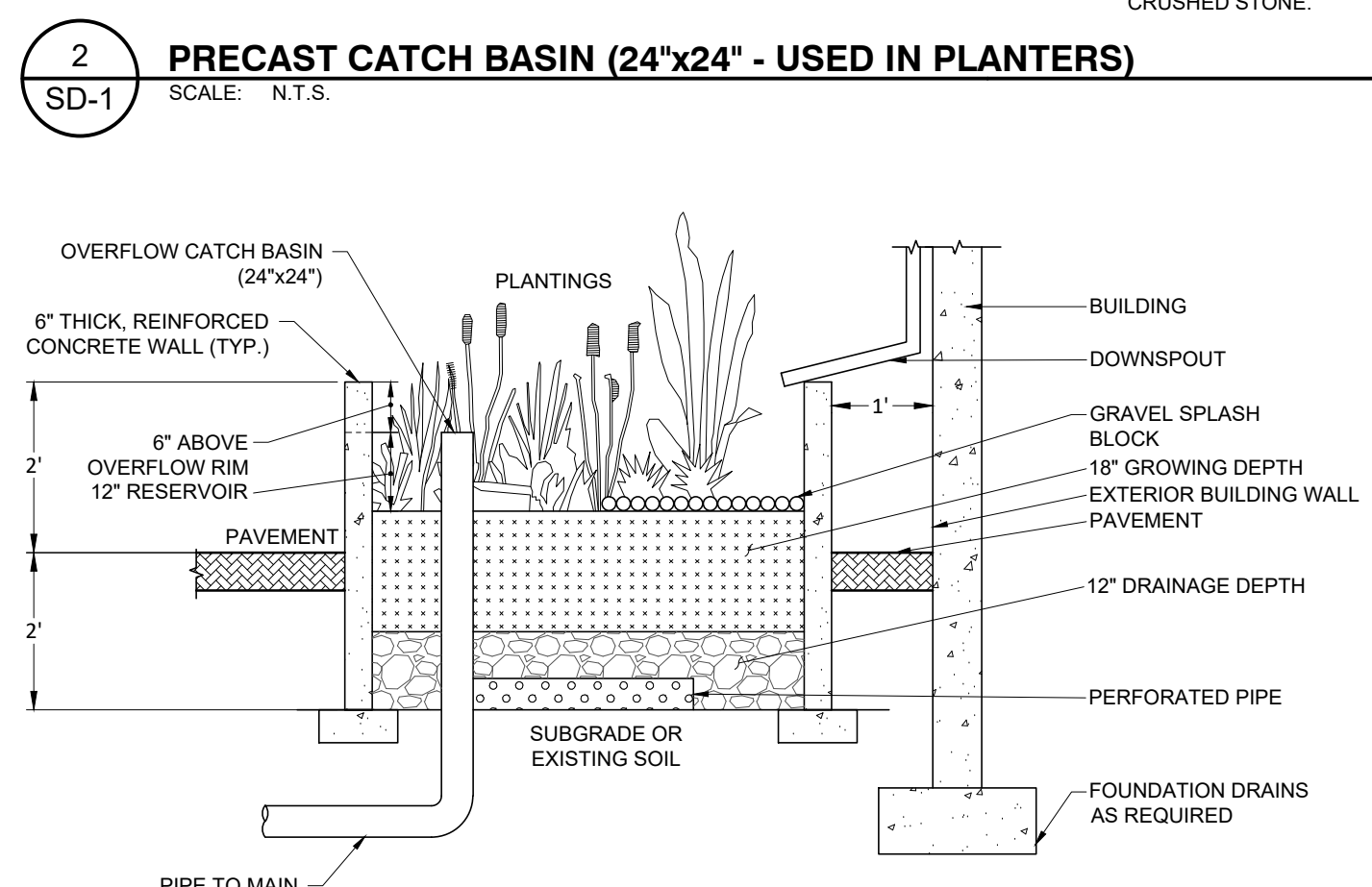

3 FLOW-THROUGH STORMWATER PLANTER DETAIL (NYSDEC)
SCALE: N.T.S.

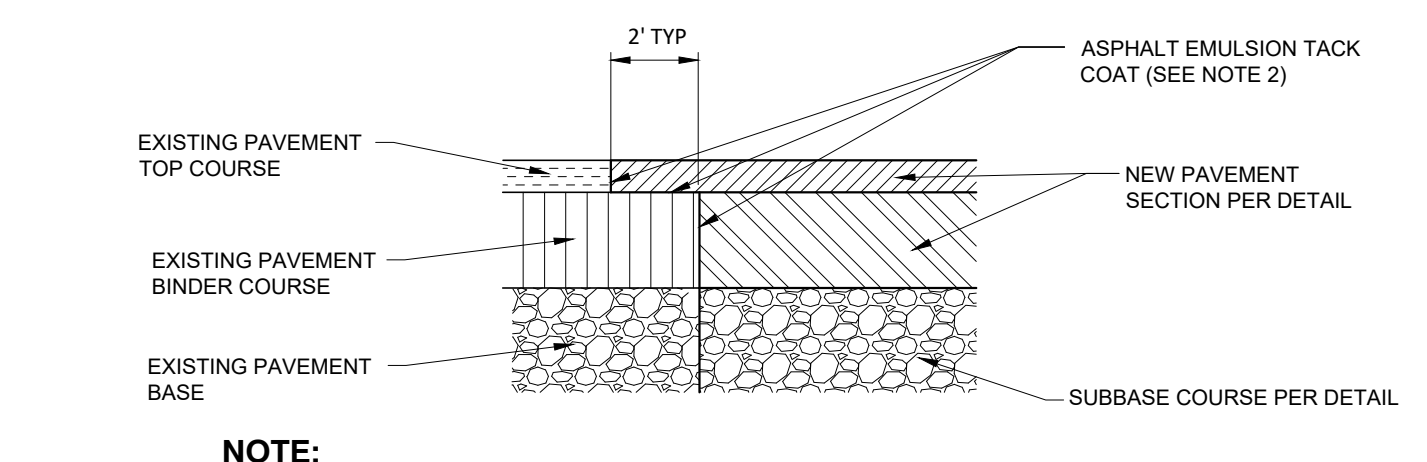

5 SAWN JOINT DETAIL
SCALE: N.T.S.

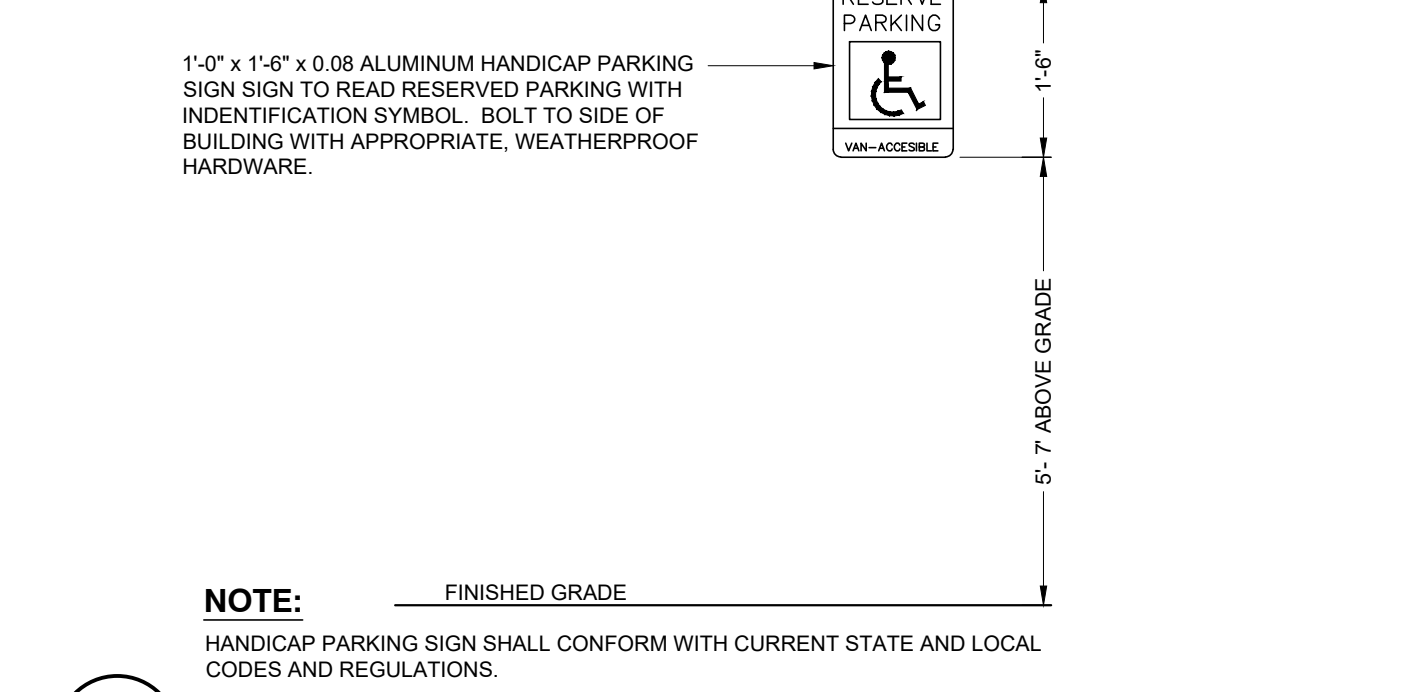

7 HANDICAP PARKING SIGN DETAIL
SCALE: N.T.S.

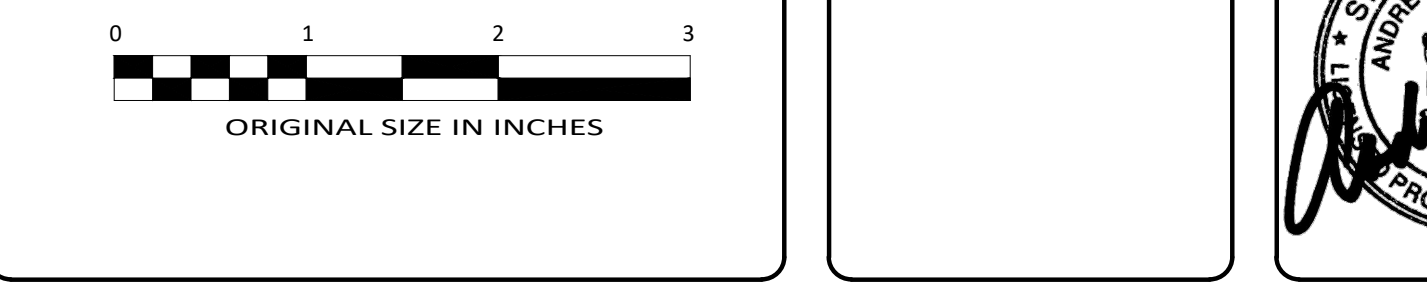

8 HANDICAP PARKING AREA DETAIL
SCALE: N.T.S.

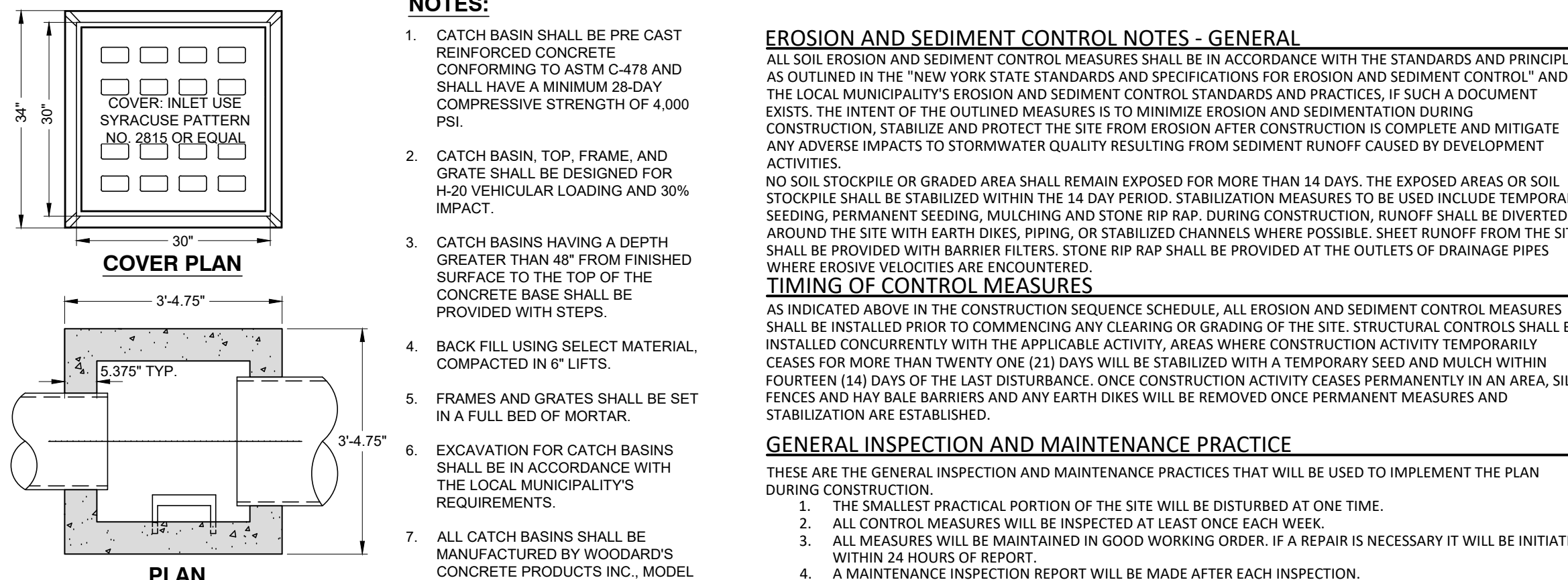

4 STORMWATER TRENCH DETAIL
SCALE: N.T.S.

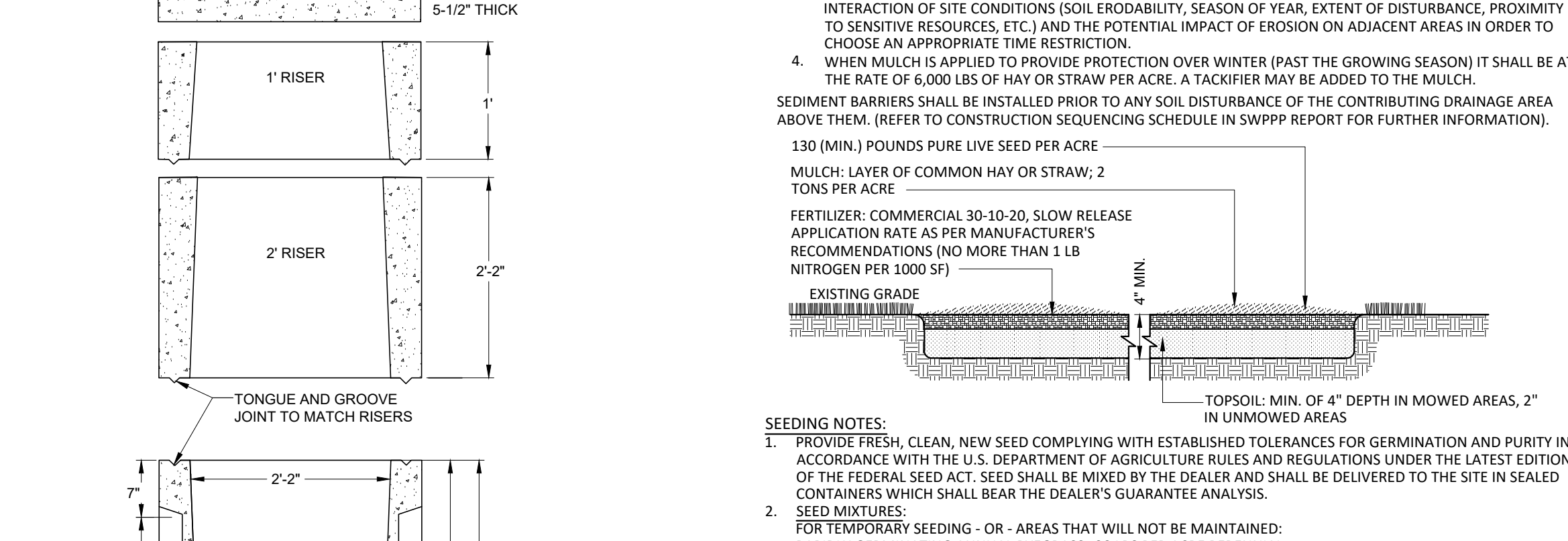

6 PARKING LOT PAVEMENT DETAIL
SCALE: N.T.S.

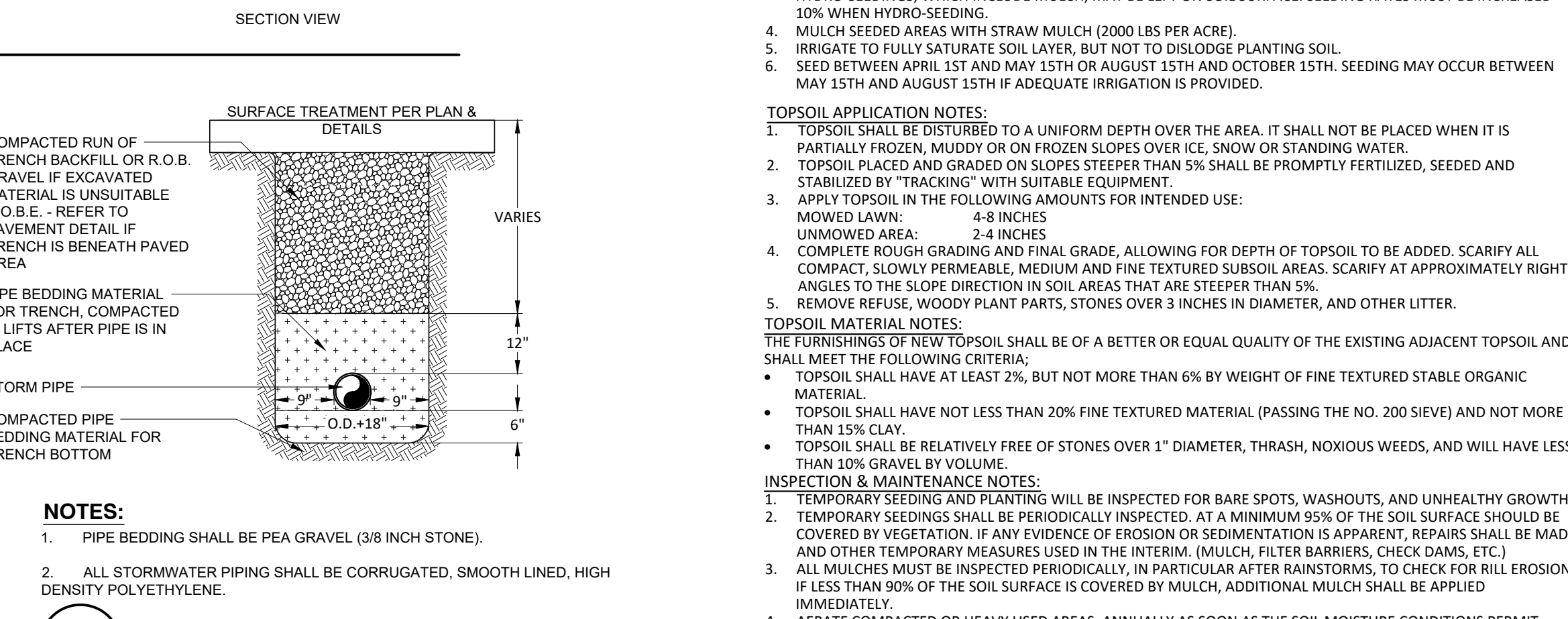

9 GRASS LINED SWALE SECTION
SCALE: N.T.S.

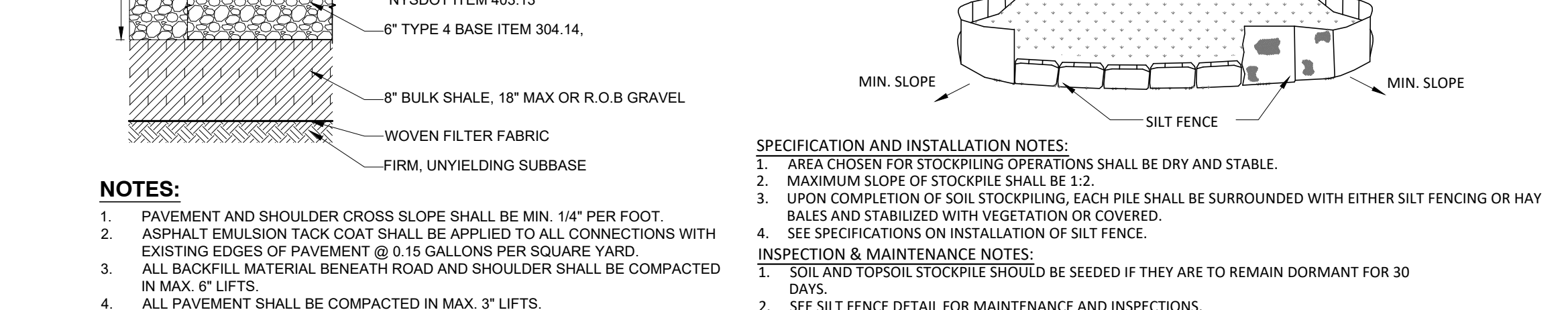

STONE CHECK DAM DETAIL
SCALE: N.T.S.

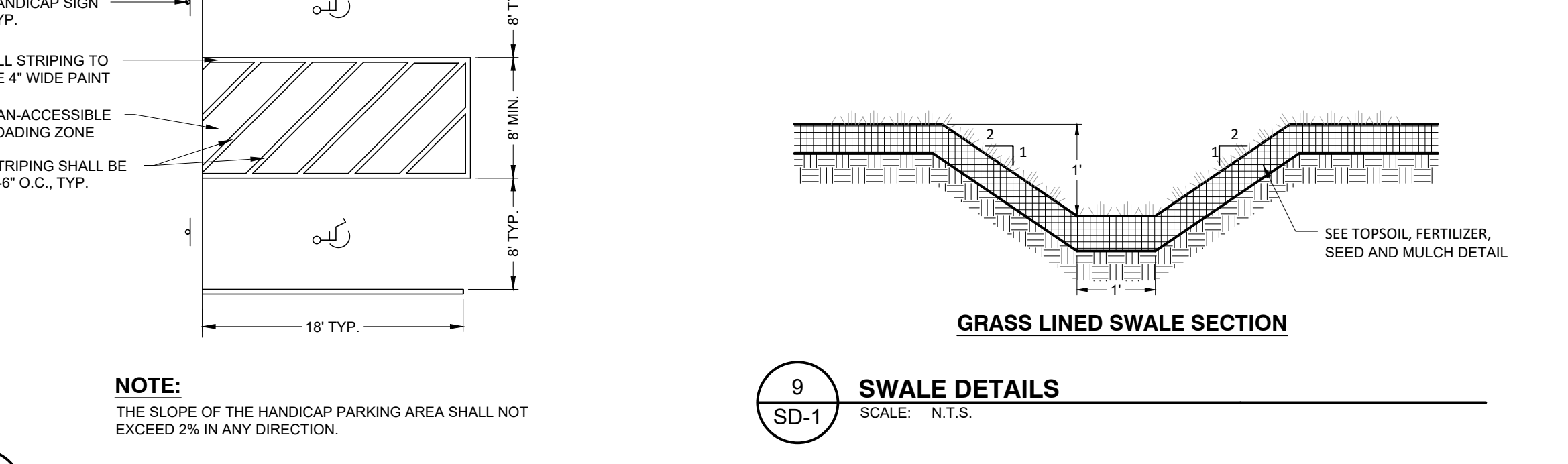

RIRAP OUTLET PROTECTION DETAIL
SCALE: N.T.S.

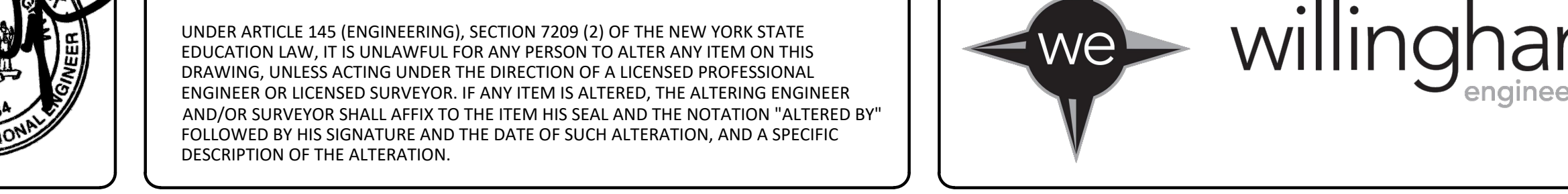

STONE CHECK DAM DETAIL
SCALE: N.T.S.

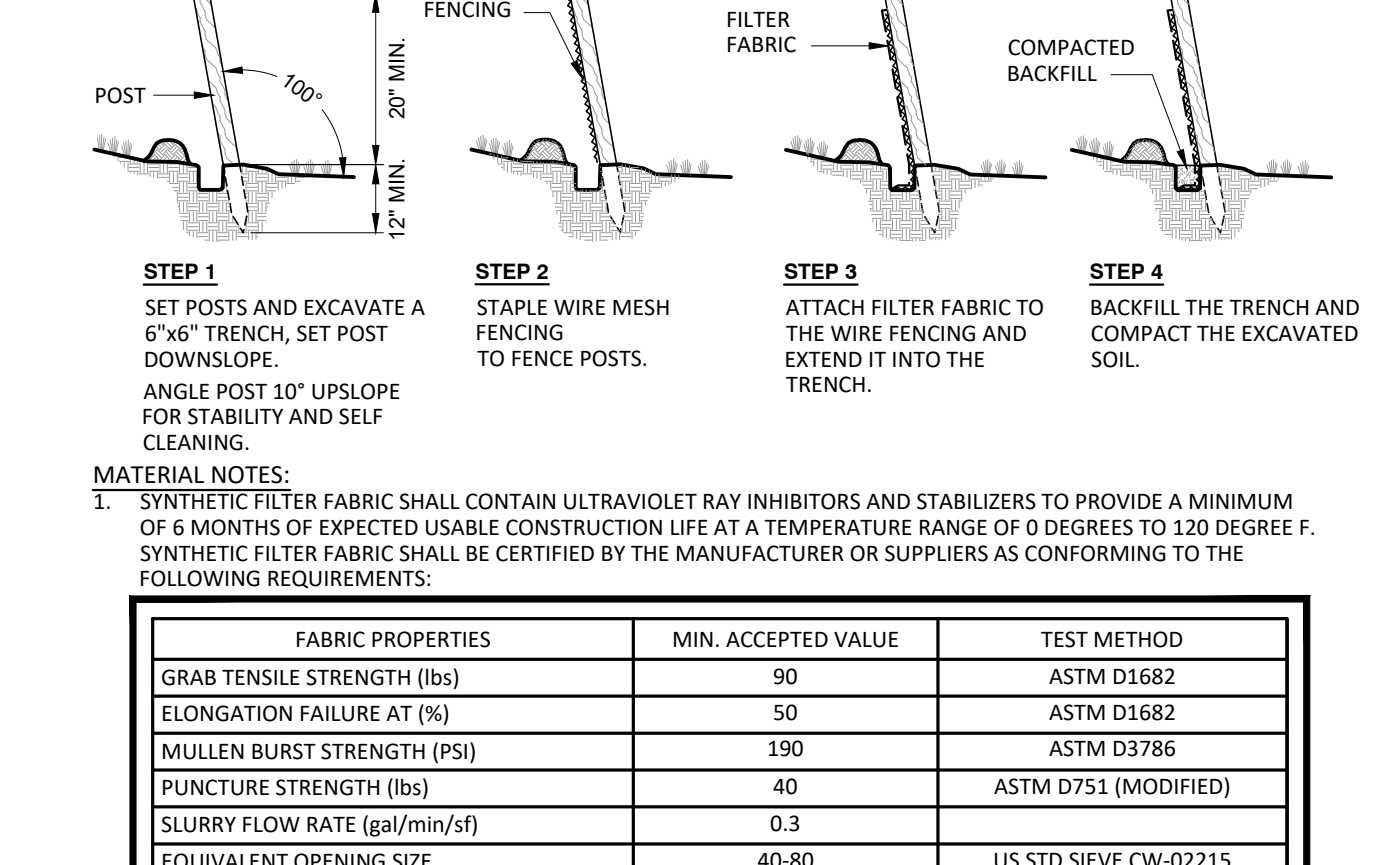

1 PRECAST CATCH BASIN (30"x30" - USED IN PARKING AREAS)
SCALE: N.T.S.

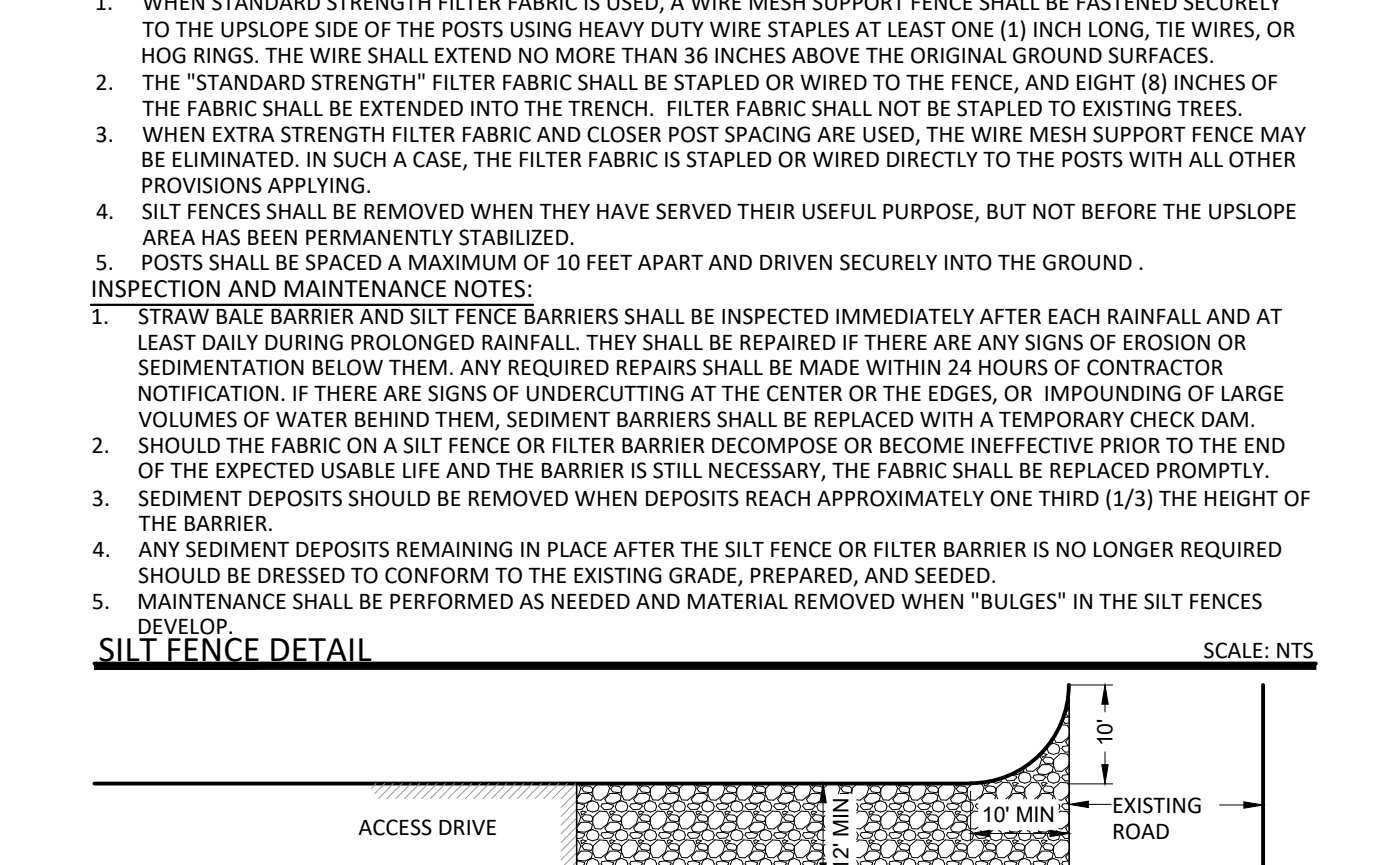

2 PRECAST CATCH BASIN (24"x24" - USED IN PLANTERS)
SCALE: N.T.S.

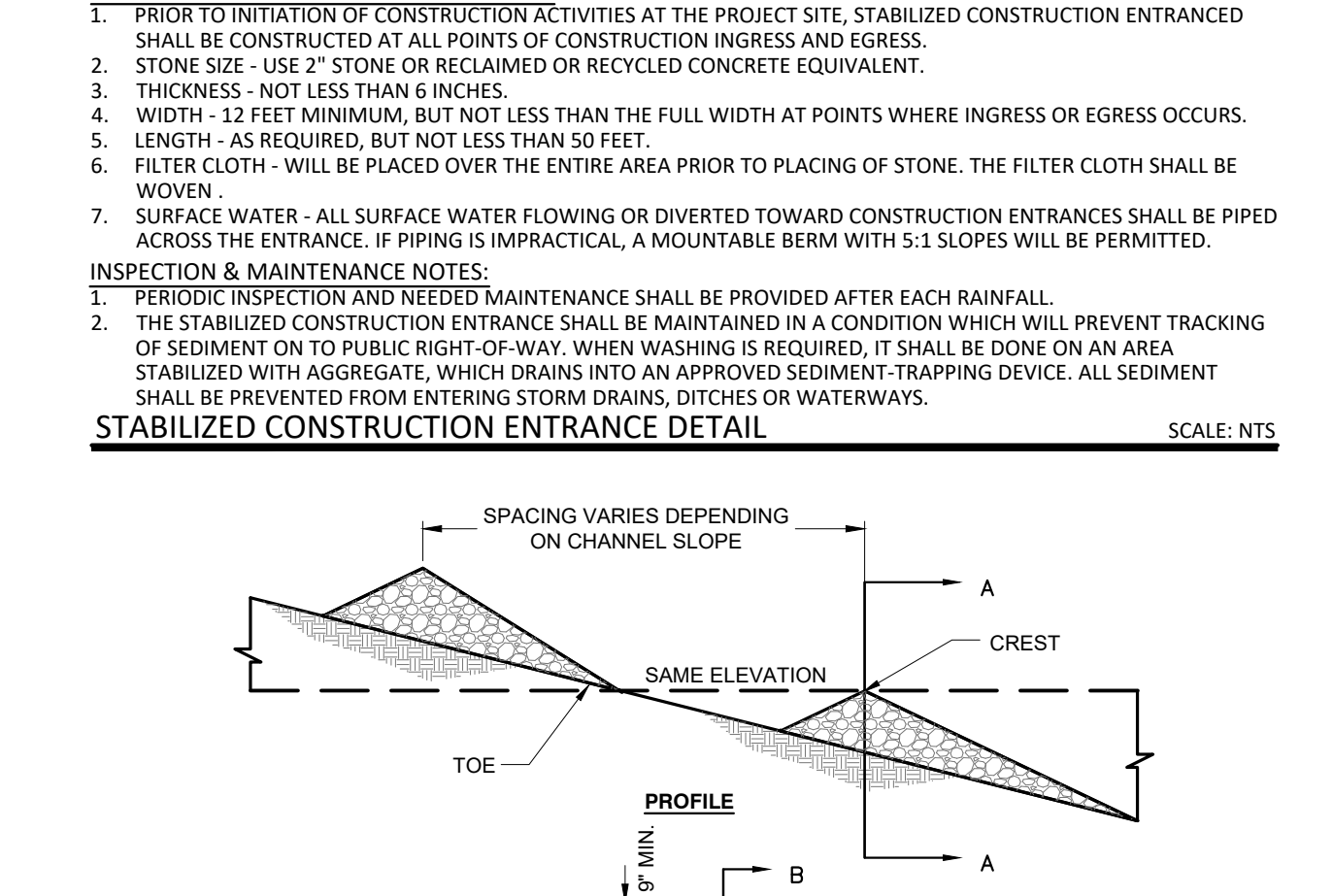

3 FLOW-THROUGH STORMWATER PLANTER DETAIL (NYSDEC)
SCALE: N.T.S.

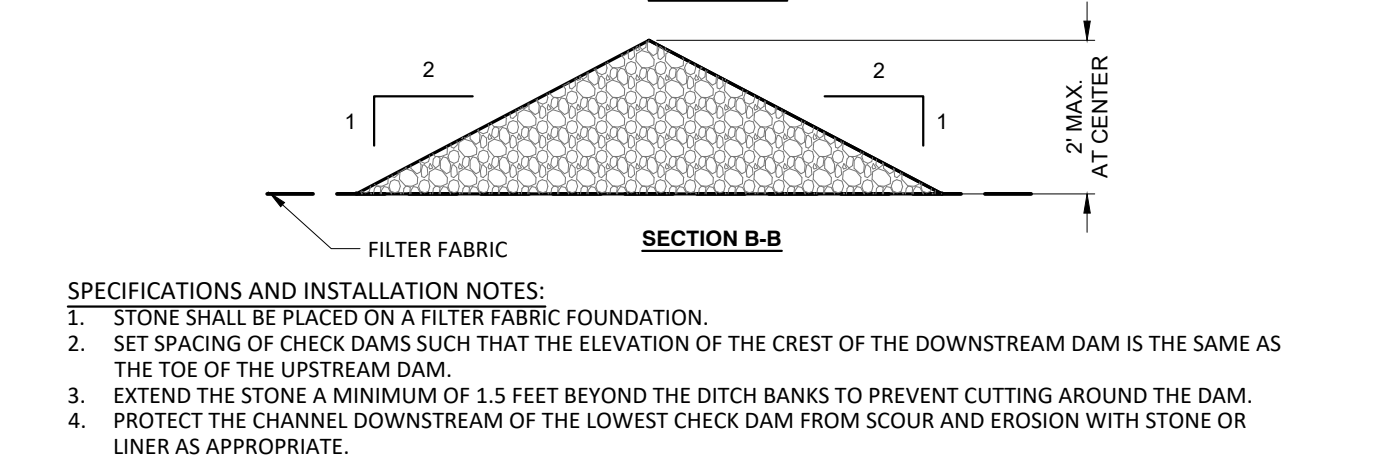

5 SAWN JOINT DETAIL
SCALE: N.T.S.

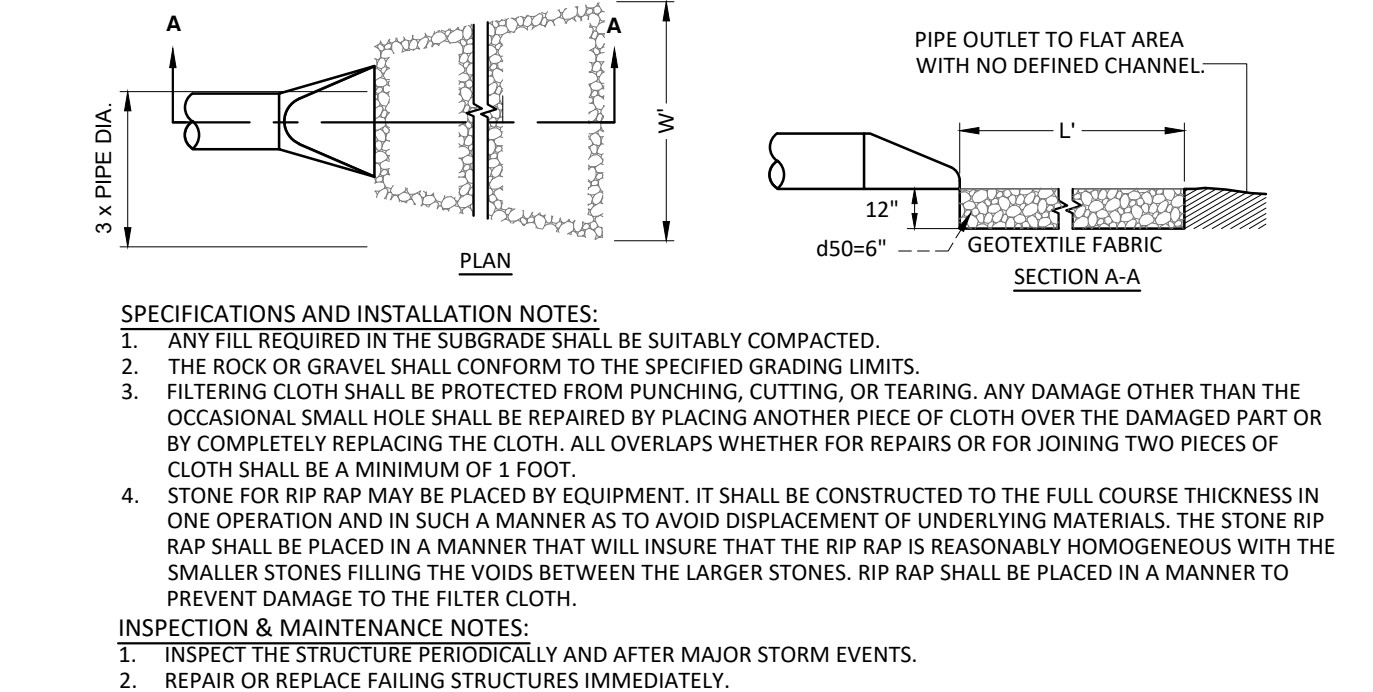

7 HANDICAP PARKING SIGN DETAIL
SCALE: N.T.S.

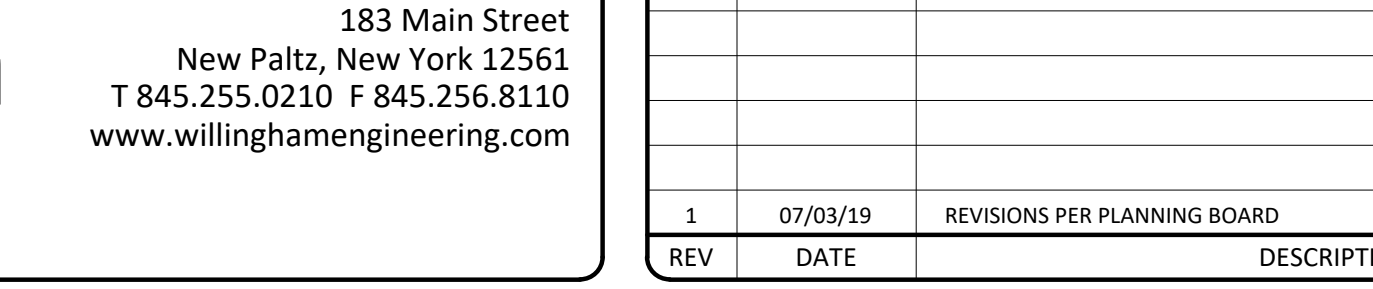

8 HANDICAP PARKING AREA DETAIL
SCALE: N.T.S.

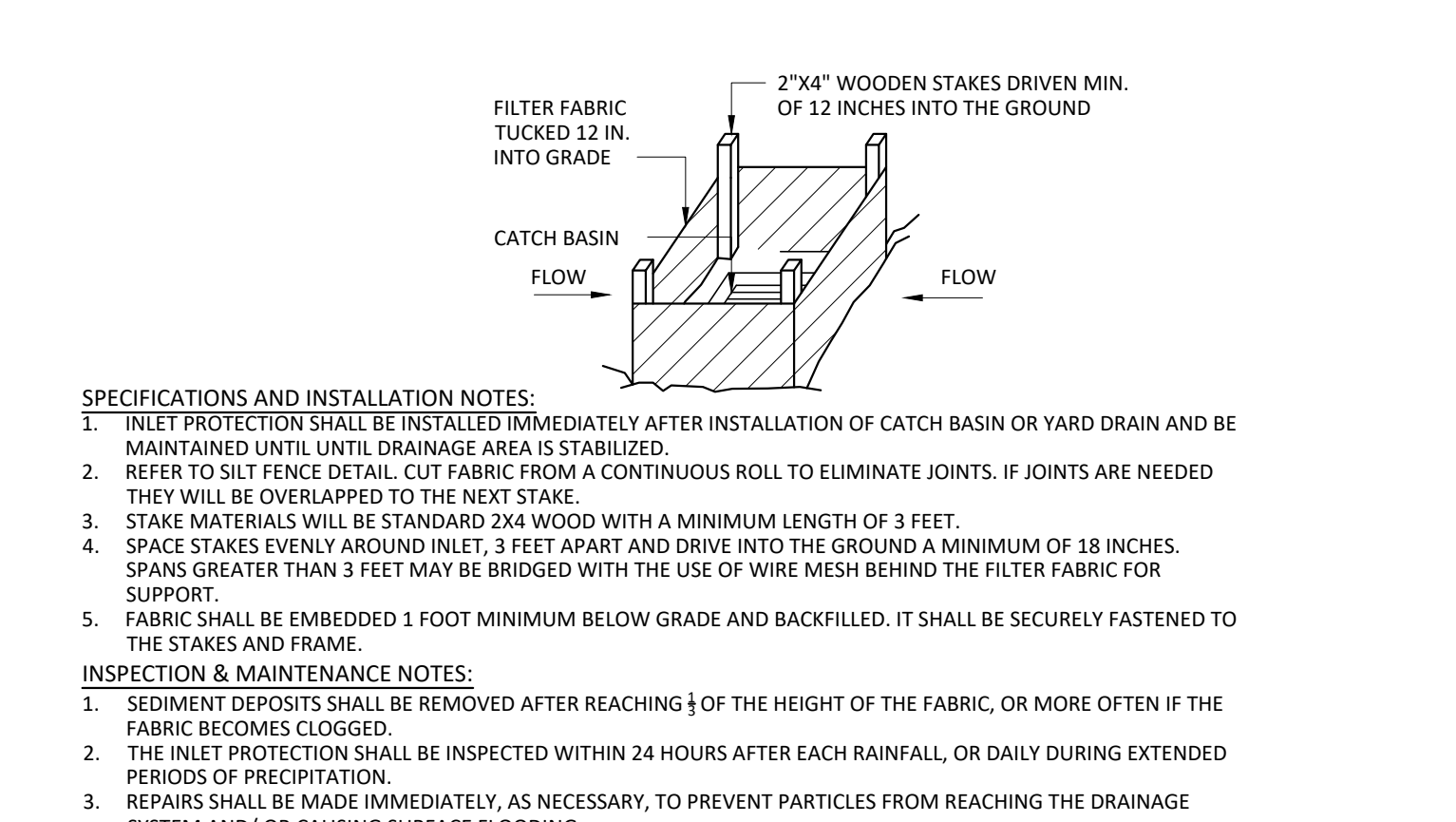

1 PRECAST CATCH BASIN (30"x30" - USED IN PARKING AREAS)
SCALE: N.T.S.

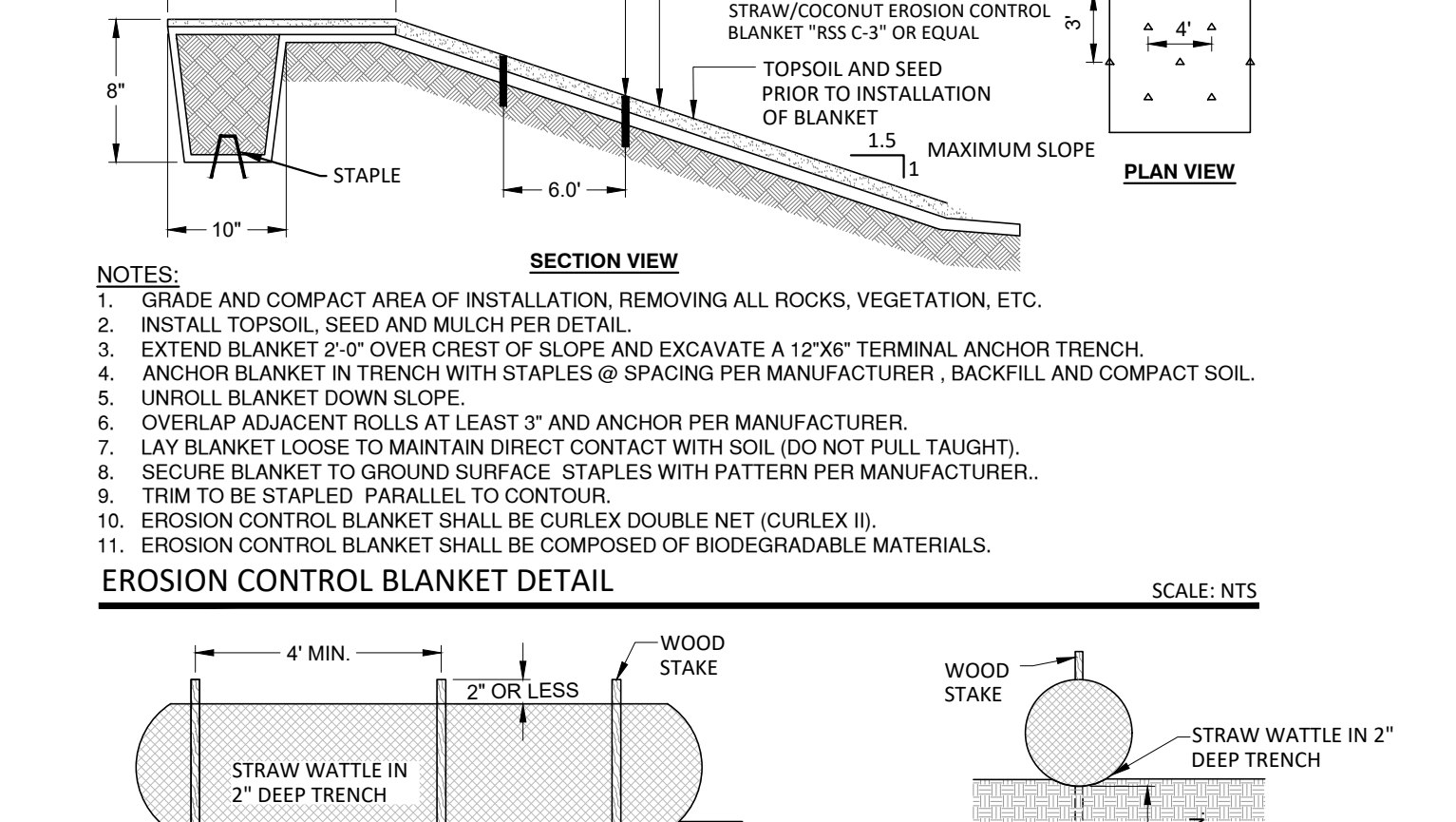

2 PRECAST CATCH BASIN (24"x24" - USED IN PLANTERS)
SCALE: N.T.S.

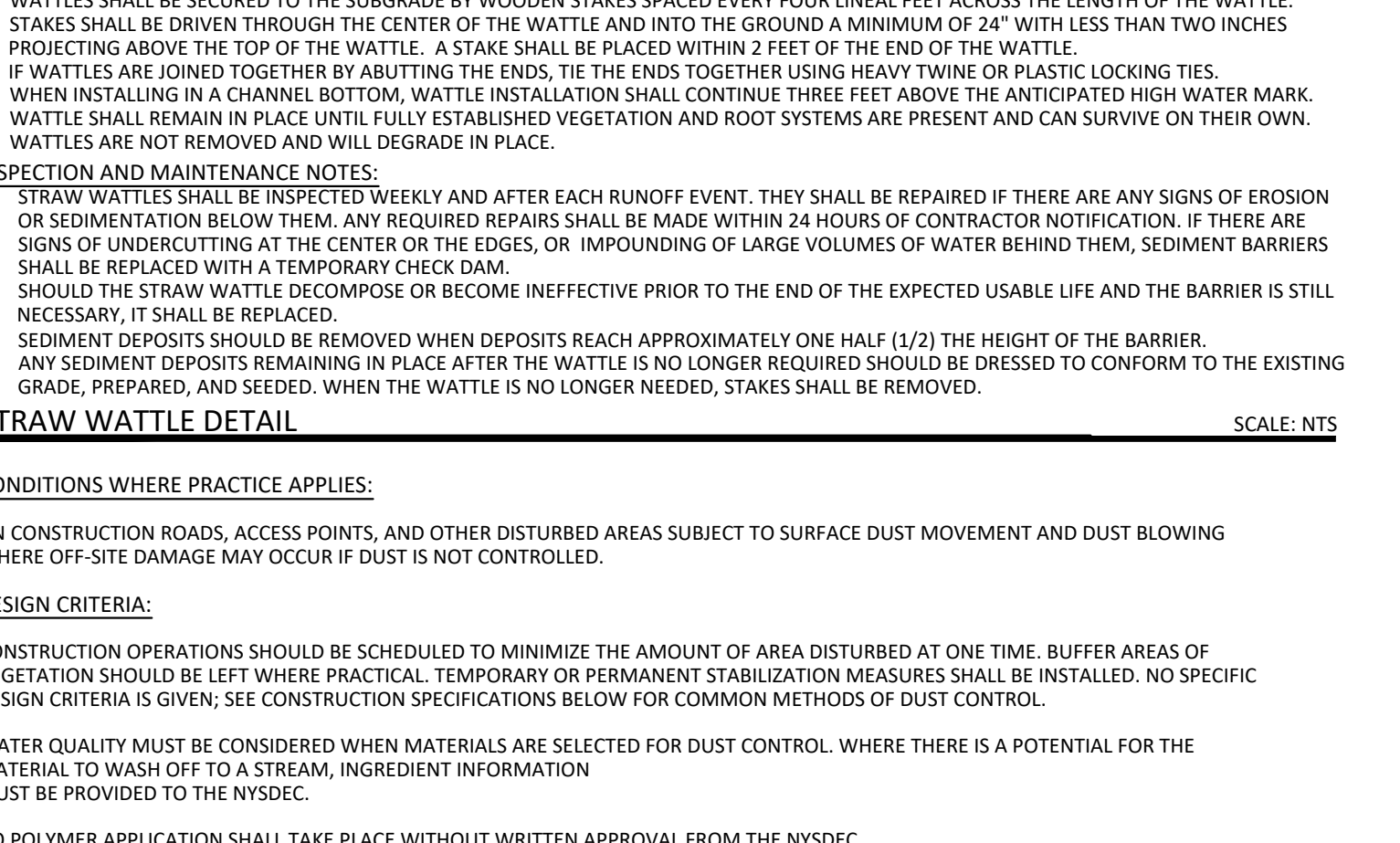

3 FLOW-THROUGH STORMWATER PLANTER DETAIL (NYSDEC)
SCALE: N.T.S.

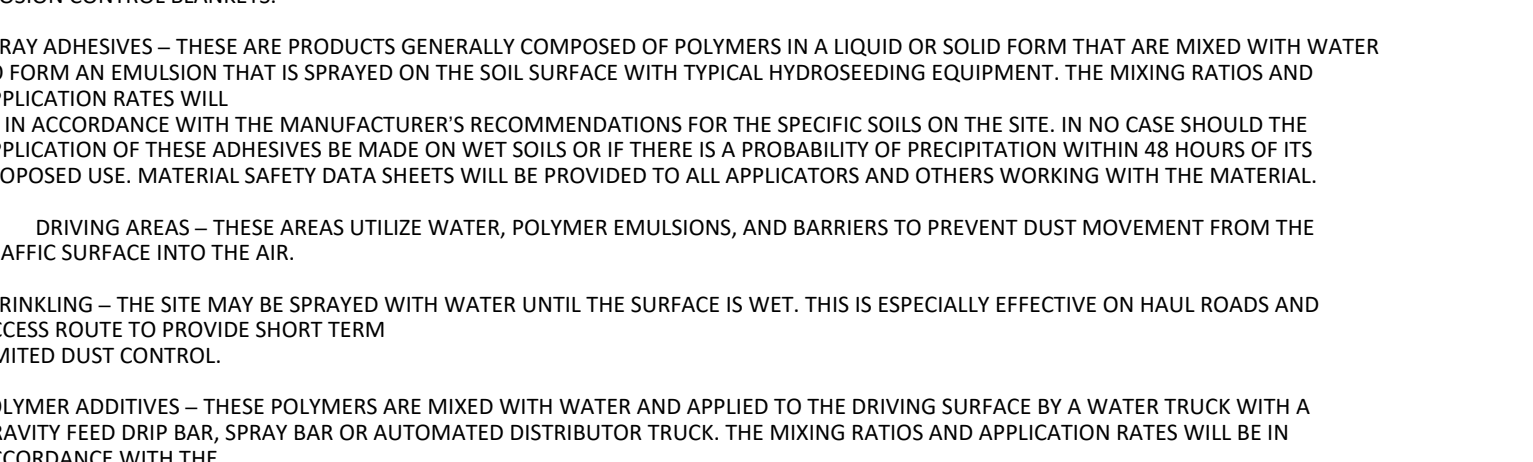

5 SAWN JOINT DETAIL
SCALE: N.T.S.

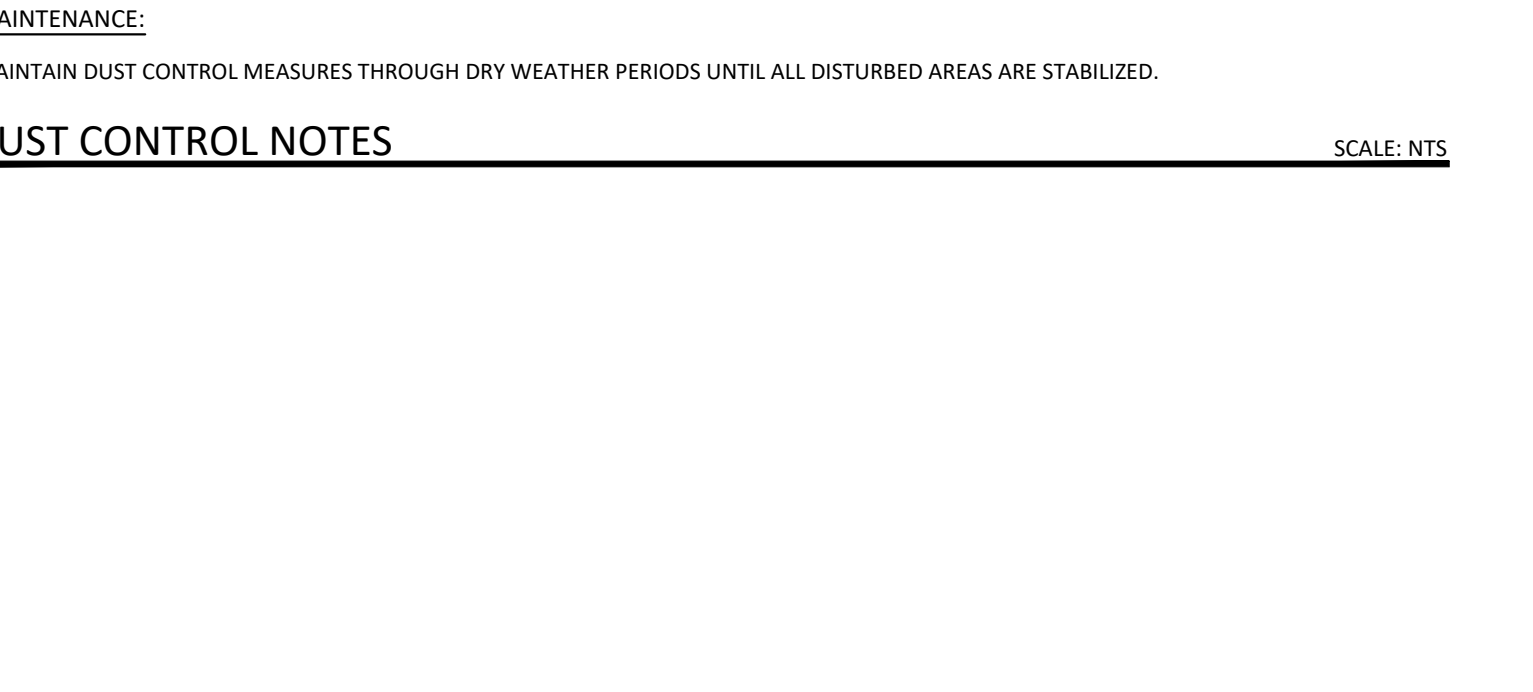

7 HANDICAP PARKING SIGN DETAIL
SCALE: N.T.S.

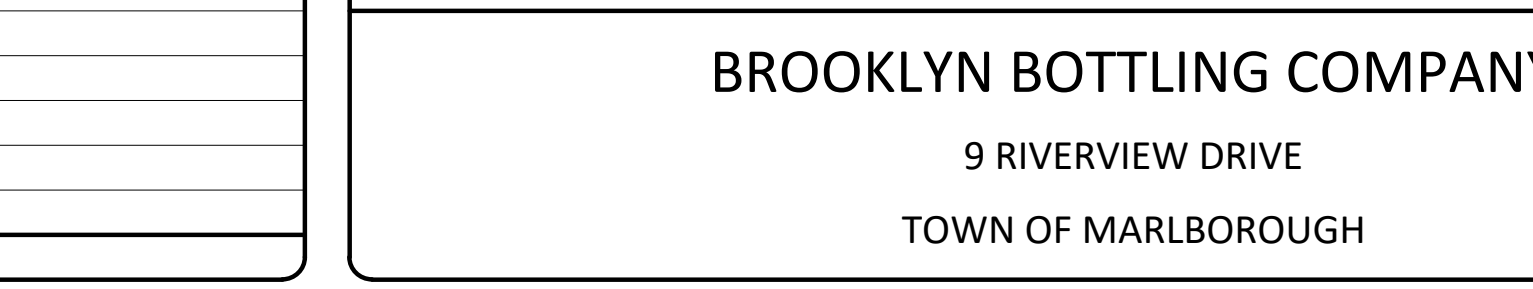

8 HANDICAP PARKING AREA DETAIL
SCALE: N.T.S.

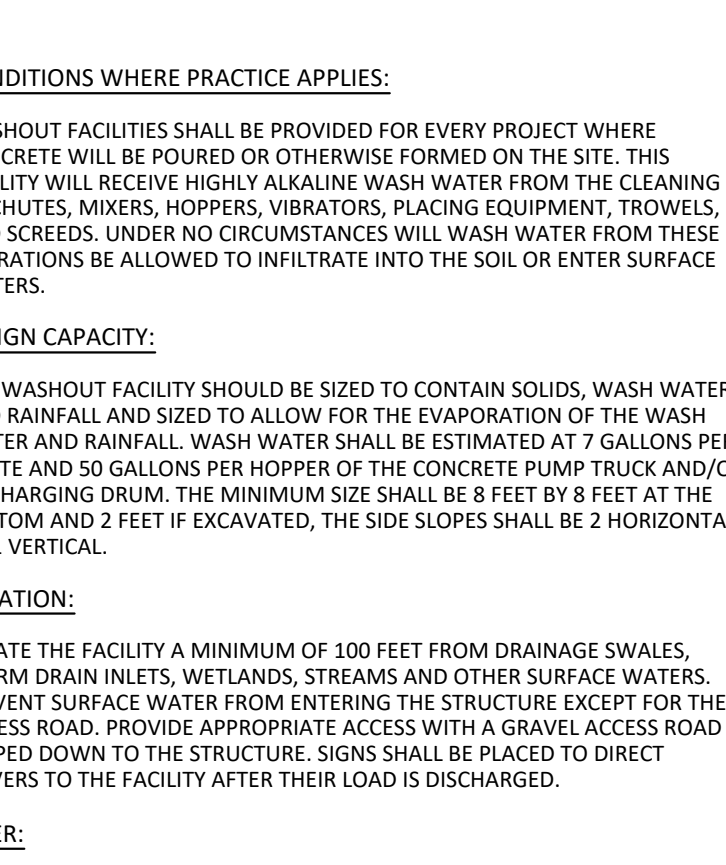

1 PRECAST CATCH BASIN (30"x30" - USED IN PARKING AREAS)
SCALE: N.T.S.

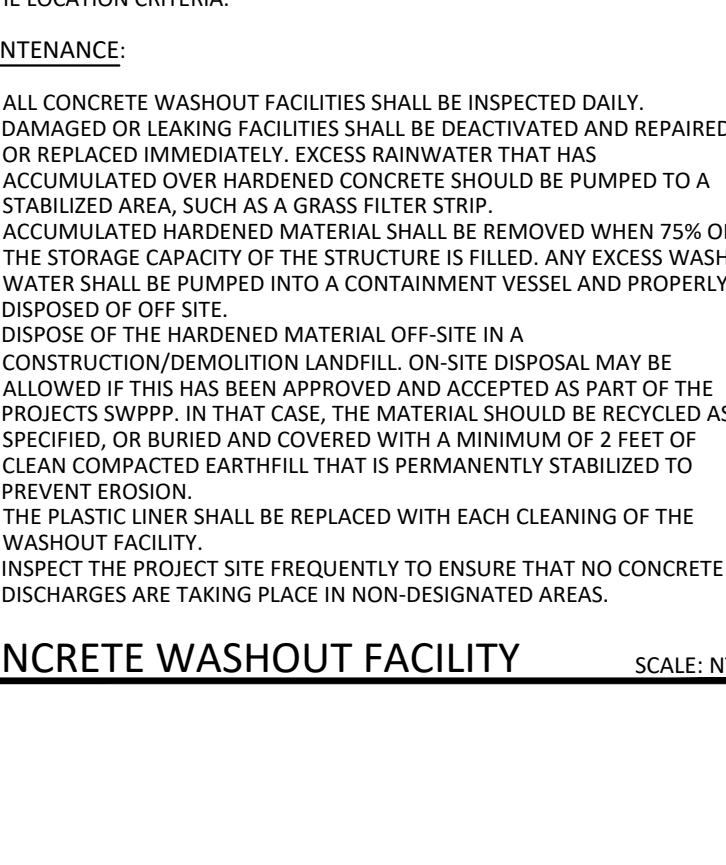

2 PRECAST CATCH BASIN (24"x24" - USED IN PLANTERS)
SCALE: N.T.S.



3 FLOW-THROUGH STORMWATER PLANTER DETAIL (NYSDEC)
SCALE: N.T.S.



5 SAWN JOINT DETAIL
SCALE: N.T.S.



7 HANDICAP PARKING SIGN DETAIL
SCALE: N.T.S.

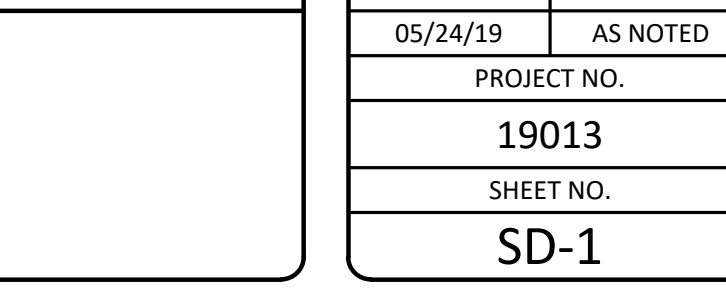

8 HANDICAP PARKING AREA DETAIL
SCALE: N.T.S.

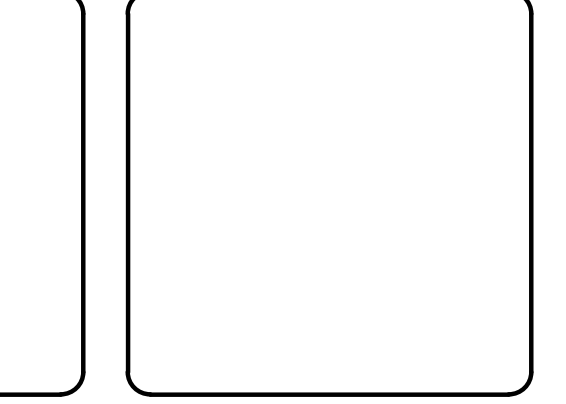
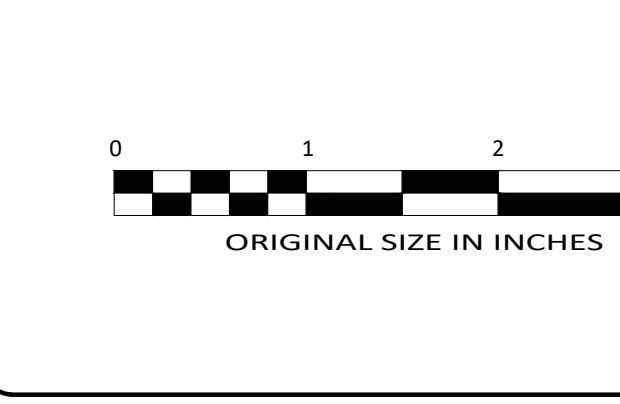

ALL RIGHTS RESERVED. COPY OR REPRODUCTION OF THIS PLAN OR ANY PORTION THEREOF, IS PROHIBITED WITHOUT THE WRITTEN PERMISSION OF THE DESIGN ENGINEER, SURVEYOR, OR ARCHITECT.

UNDER ARTICLE 145 (ENGINEERING), SECTION 7209 (2) OF THE NEW YORK STATE EDUCATION LAW, IT IS UNLAWFUL FOR ANY PERSON TO ALTER ANY ITEM ON THIS DRAWING UNLESS ACTING UNDER THE DIRECTION OF A LICENSED PROFESSIONAL ENGINEER OR LICENSED SURVEYOR. IF ANY ITEM IS ALTERED, THE ALTERING ENGINEER AND/OR SURVEYOR SHALL AFFIX TO THE ITEM HIS SEAL AND THE NOTATION "ALTERED BY" FOLLOWED BY HIS SIGNATURE AND THE DATE OF SUCH ALTERATION, AND A SPECIFIC DESCRIPTION OF THE ALTERATION.

willingham engineering

183 Main Street
New Paltz, New York 12561
T 845.255.0210 F 845.256.8110
www.willinghamengineering.com

| REV | DATE | REVISIONS PER PLANNING BOARD | DESCRIPTION |
|-----|----------|------------------------------|-------------|
| 1 | 07/03/19 | | |

SITE DETAILS

BROOKLYN BOTTLING COMPANY

9 RIVERVIEW DRIVE
TOWN OF MARLBOROUGH

| DRAWN BY | CHECKED BY |
|-------------|------------|
| MLT | AWW |
| DATE | SCALE |
| 05/24/19 | AS NOTED |
| PROJECT NO. | |
| 19013 | |
| SHEET NO. | |
| SD-1 | |